LOXCAR



LOXCAR ?

LOXCAR ?

❖ Loxcar

❖ Loxcar

가

❖ Loxcar 6

LED

2

LED

가

가 ,

12V

❖ Loxcar

IC Chip

가

가

Interior

LOXCAR

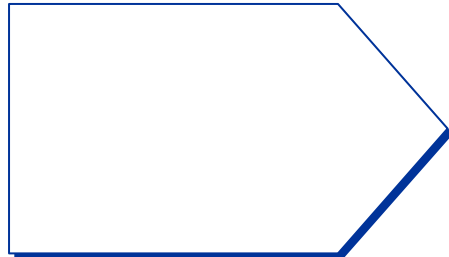

Loxcar
가 .



Loxcar IC Chip
가 .

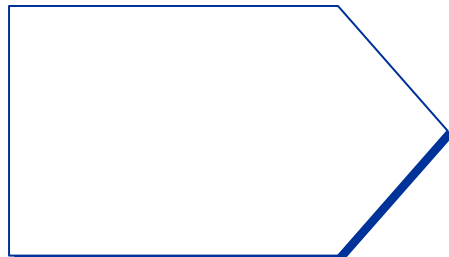

Loxcar .

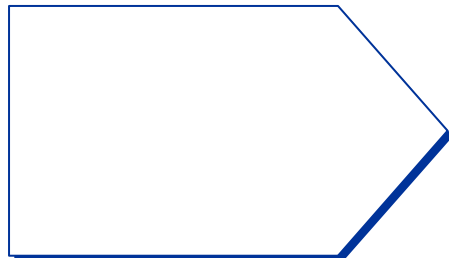

Loxcar LED .

LOXCAR

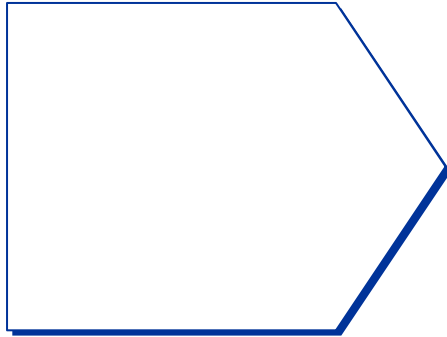

- ❖ 25%
- ❖
- ❖ 가
- ❖

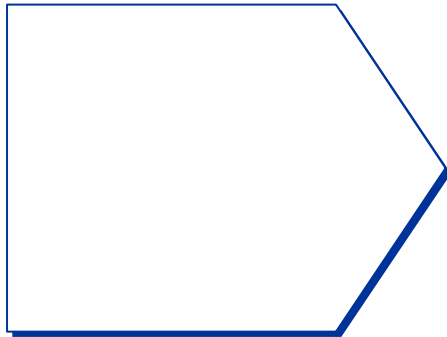

- ❖
- ❖
- ❖
- ❖

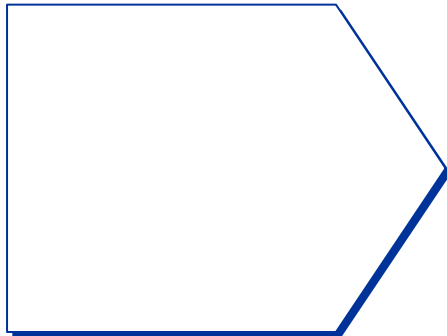

- ❖ Sensor
- ❖ (HEIMANN)
- ❖ (/ LED)
- ❖ (/ LED)

LOXCAR



	가		
Loxcar	154,000		
A	150,000		
B	660,000		ECU
C	420,000	가	
D	300,000		
E	190,000	ECU ECU	

LOXCAR

❖ Loxcar

❖

Loxcar

❖ Loxcar

DC

❖

가

❖

“ !

!”

가

가

Loxcar가

“

.” 가

1.

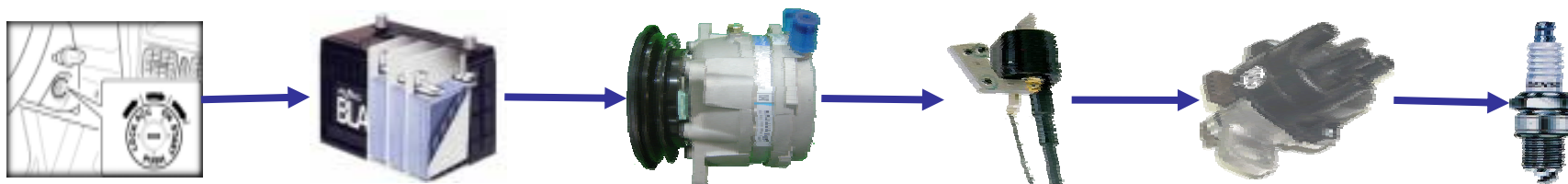

가

2 V

가

2.

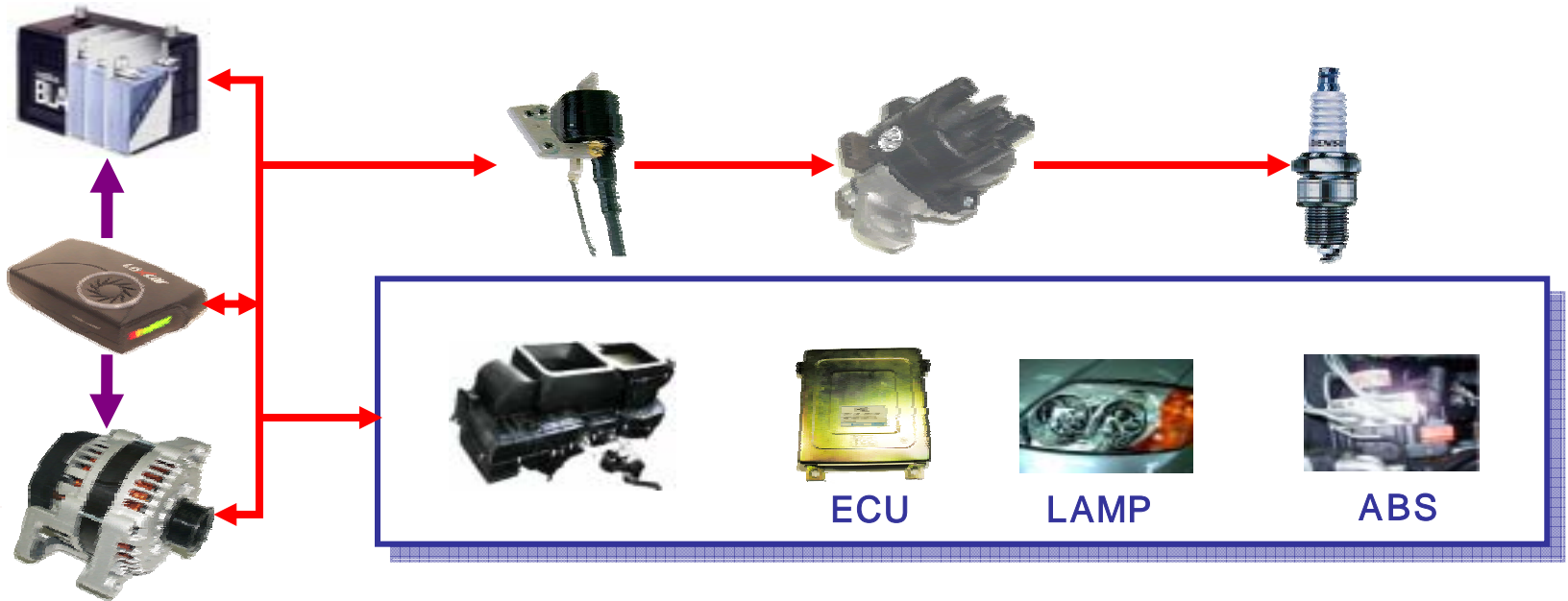

가

. Loxcar

가

DIAGRAM

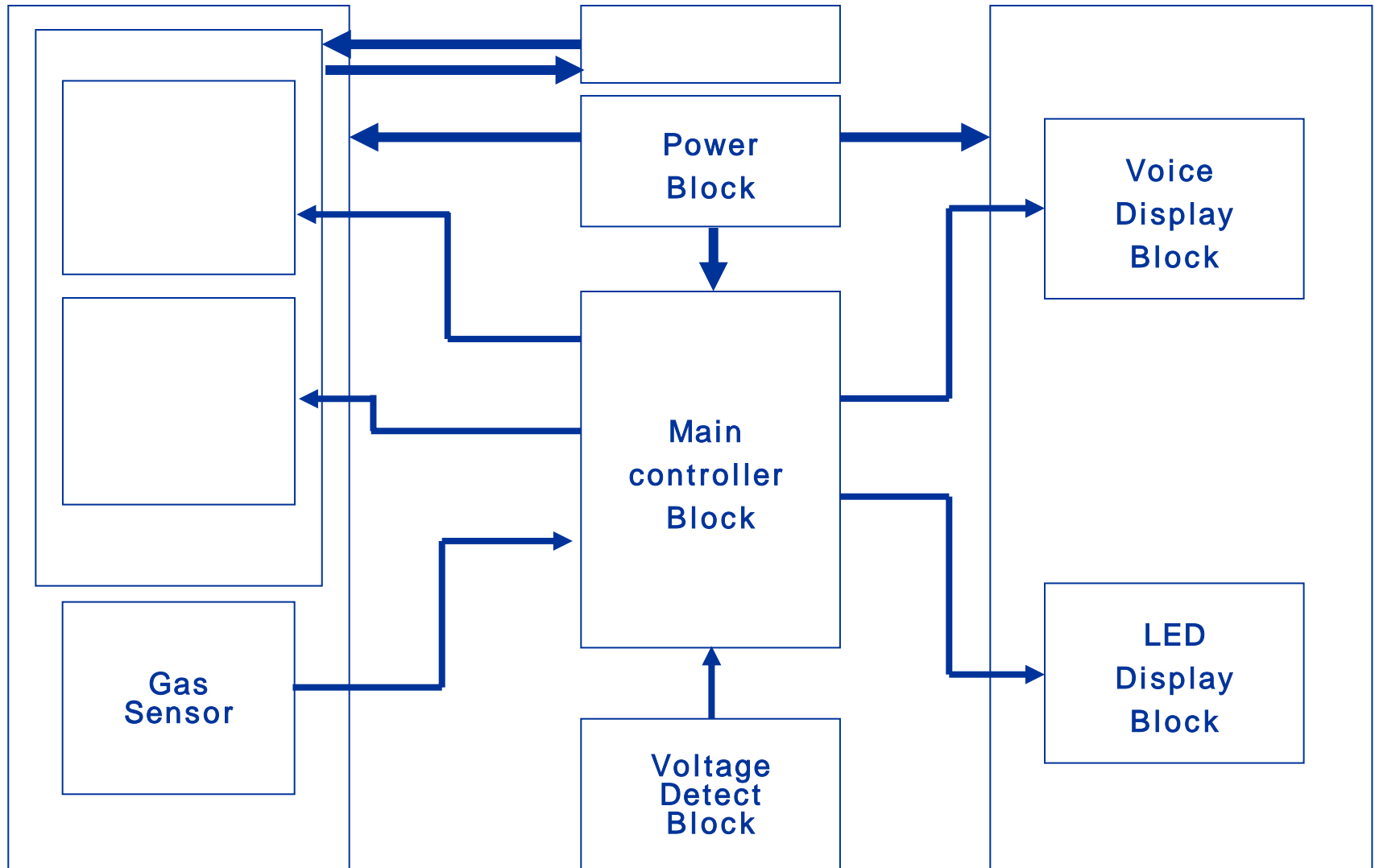

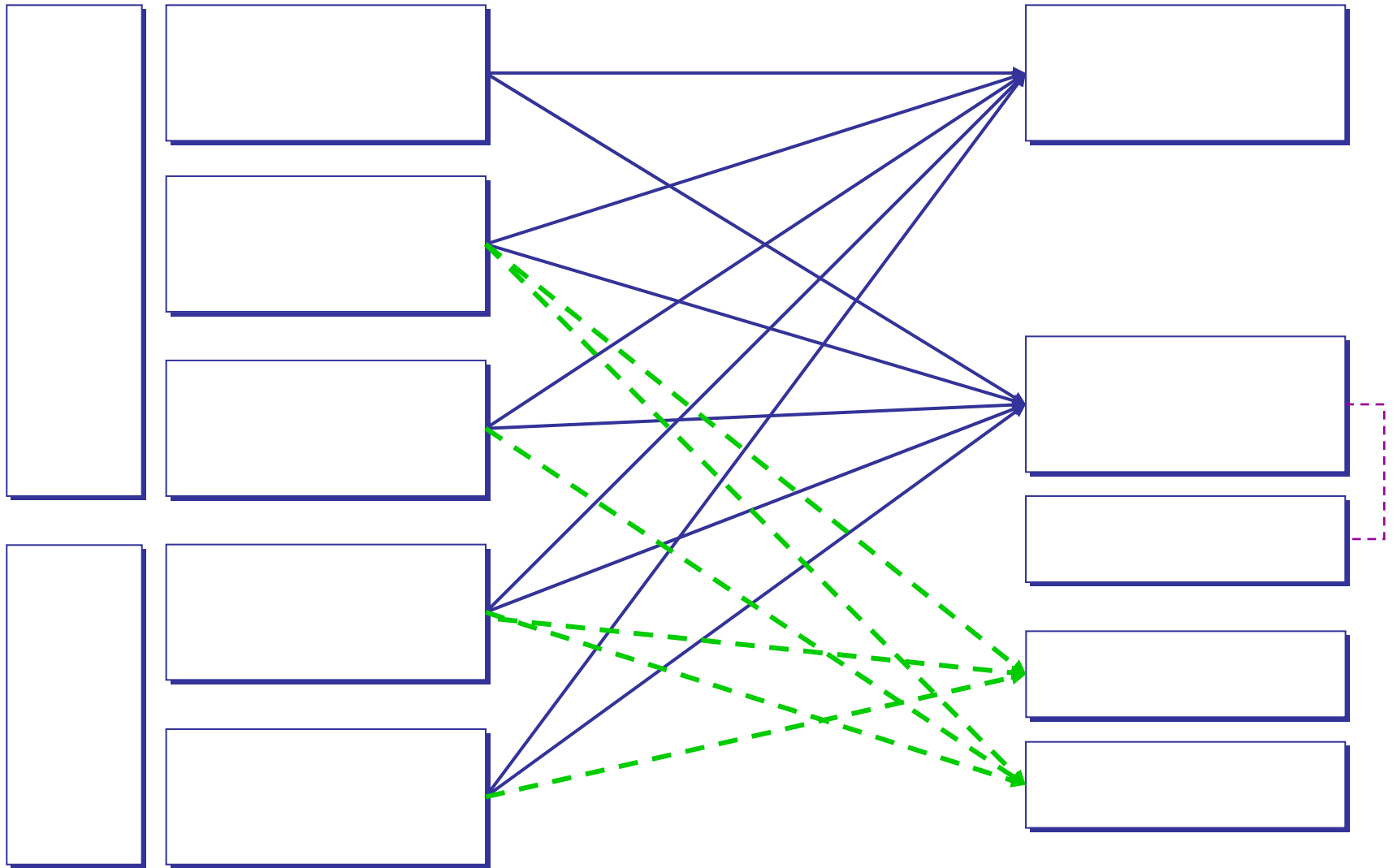



(Alternator)
(RPM)가 가

가

가

❖ Loxcar

가



Loxcar

가

1.

❖ 가 가

. 가

가 .

❖ . .

❖ Loxcar 1

가

. .

2.

❖ 가 가

.

가

❖ .

.

❖ Loxcar

1

가

.

.

3.



가

❖ Loxcar

❖ 50% 60% 90% 95%
?

❖ 가

❖ !

가 . .

❖ Loxcar 2
가 ()
()

	,	
	가 가 가	() , ()
	가	

LOXCAR ?

- ❖ 가 가 . 가 .
- 가 가

- ❖ Loxcar

Thermopile IR Sensor

- ❖ 가 “ 가 “ !” , 가 “ !” .

- ❖
- ❖ 가
- ❖ 2 cc 2 2700ppm (356ppm) 7 . (California Air Resources Board (CARB) & South Coast Air Quality Management District (SCAQMD) 2)
- ❖ 가
- 가 . 가
- 가



가

CO2 (%)	
2.5	
3.0	가
4.0	
6.0	가
8.0	
10.0	
20.0	가



21%	
18%	
16 12%	가,
14 9%	(Zyanose),
10 6%	,
10 6%	6 8

: 가

CO2 Gas Sensor ?

- ❖ Loxcar
(Infra-red, IR)
2

(Thermopile)

CO

- ❖ Thermopile IR Sensor

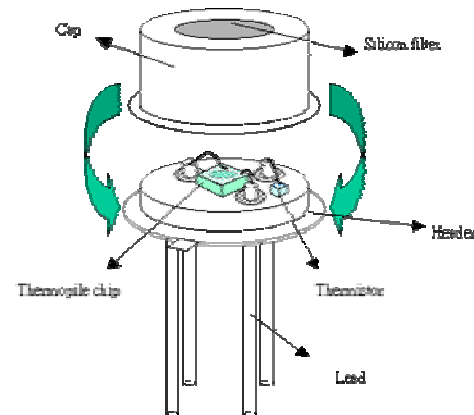
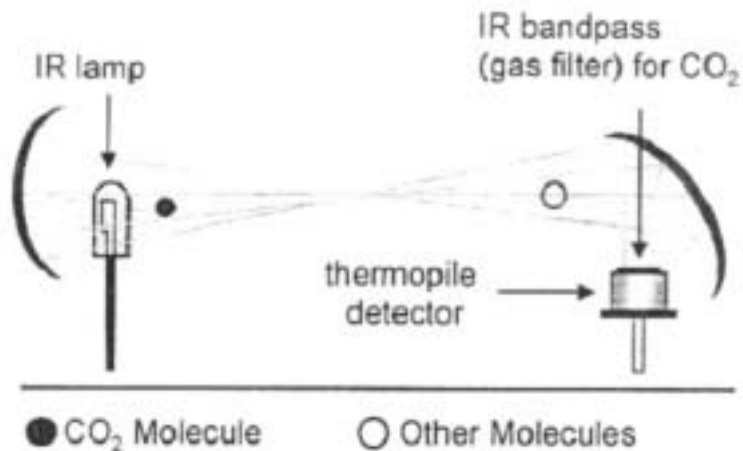

: 10-0610552-000

PCT : PCT/KR2006/001278

FCC : FCC47 Part 15 subpart B (Class A)

: ISO 9001 , ISO14001



실용신안등록증

CERTIFICATE OF UTILITY MODEL REGISTRATION

등록번호 REGISTRATION NUMBER	0398974 호	출원번호 APPLICATION NUMBER	제 2005-000807 호
		출원일 FILING DATE	2005년 10월 11일
		등록일 REGISTRATION DATE	2005년 10월 11일

고안명 명칭 (TITLE OF THE DEVICE)
피洋服 시가계 전원 화상장치

실용신안권자 (OWNER OF THE UTILITY MODEL RIGHT)
등록식탈안계 기계

고안자 (inventor)
이재리(090615-2*****)
경기도 용인시 상현동 864 단원아파트3단지 심원상세빌 307-201

위의 고안은 「실용신안법」에 의하여 실용신안등록원부에
등록되었음을 증명합니다.

(THIS IS TO CERTIFY THAT THE DEVICE IS REGISTERED ON THE REGISTER OF THE KOREAN
INTELLECTUAL PROPERTY OFFICE.)

2005년 10월 11일



특
어
청

KOREAN INTELLECTUAL PROPERTY OFFICE



* 실용신안권은 "실용신안법" 제43조에 의거 「실용신안법」 제25조 제1항에 따른 등록원부상표로 만기 이전만 출원 또는 실용신안권자 명의로 출원 내서만 그 권리를 행사할 수 있습니다.

CONTACT US

:
: 02-2057-4681/7450
: 02-2057-4687
011-9024-5527
: iqbank@dinett.com, sales@dinett.com
: <http://eng.dinett.com>

: 17-1 2